

CLASS RATING	
B - 80kN	
Maximum Fill - 600mm	
EXPOSURE CLASSIFICATION	
B1	
AS3600-2001	
CONCRETE TOLERANCES	
AS 3610-1995	
LIFTING	
FA x 2.5t x 75mm	
Reid Swiftlift Anchors	
TOTAL MASS	
Top - 5.565 tonne	
Middle - 3.545 tonne	
Bottom (Cone) - 6.385 tonne	
NOTES	
* cone section shown may be cone or flat unless specified	
^ not including joint	
Locating brackets 8off 310x65x8mm Glav Plate Secure with 2No. M10 x 55mm Ramset Dynabolts	
ACCESS OPTIONS	
Standard	
Rectangular	
Other access options available, please enquire.	
Quality ISO 9001	
SAI GLOBAL	
Certificate No.: QEC4234	
ISO 9001:2008	

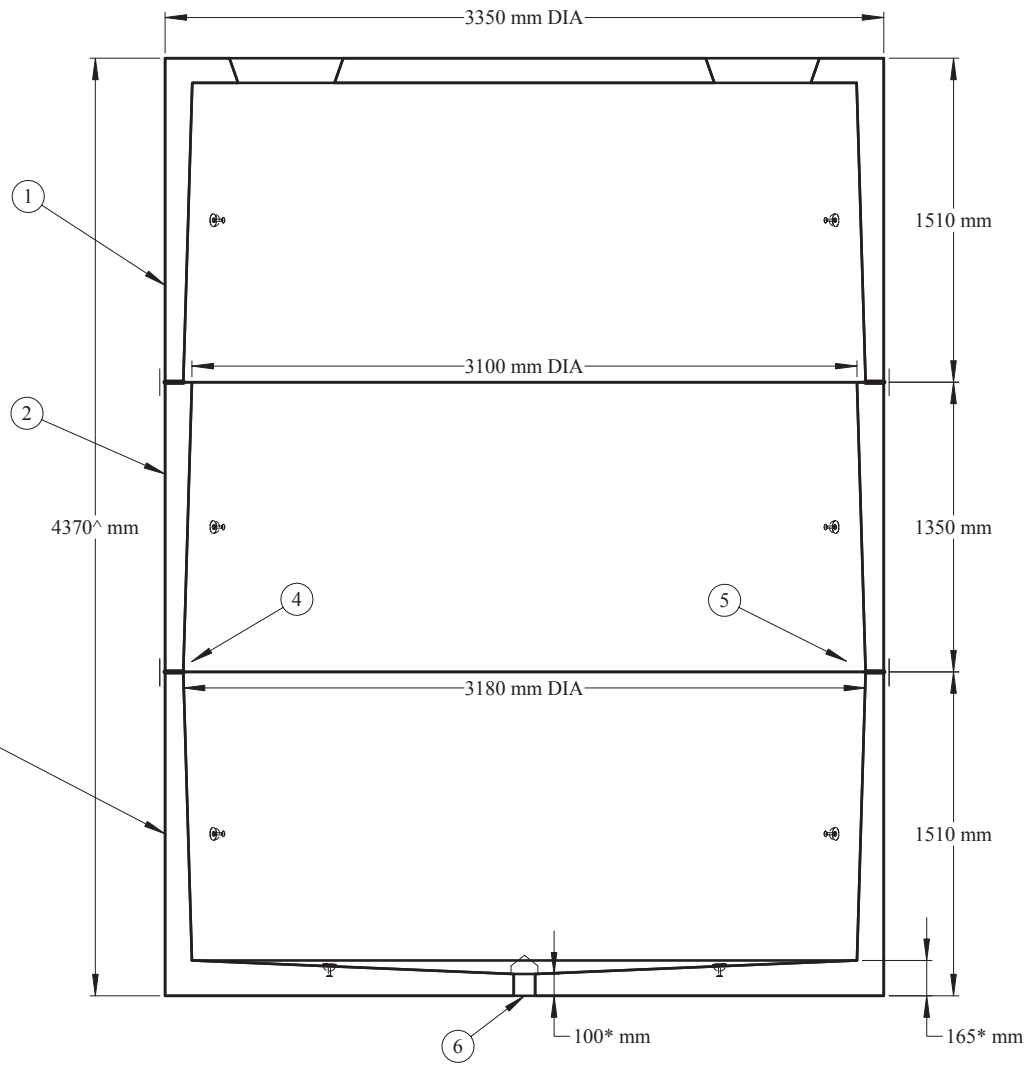

SECTION A-A

32,000 Litre Universal Tank in 3 Sections Class B



TANKET
 Cnr Bayfield Rd East & Canterbury Rd,
 Bayswater North 3153 Vic Australia
 T: 1300 826 538 www.tanket.com.au